



Product Summary

$V_{(BR)DSS}$	$R_{DS(on)TYP}$	I_D
200V	81mΩ@10V	28A

Feature

- Trench Technology Power MOSFET
- Low $R_{DS(on)}$
- Low Gate Charge
- Low Gate Resistance
- 100% UIS Tested

Application

- Power Switching Application

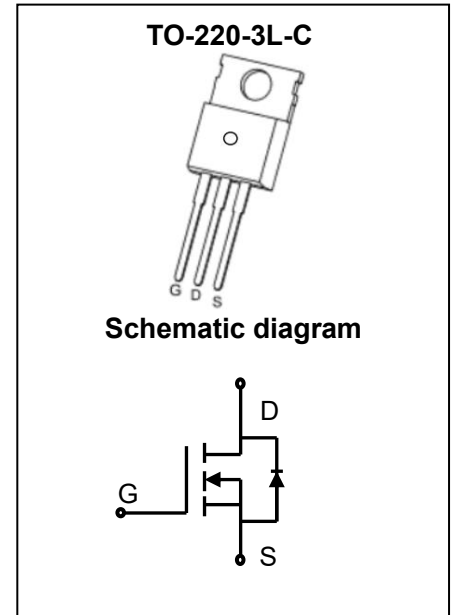

Package Marking and Ordering Information

Part Number	Package	Marking	Packing	Reel Size	Tape Width	Qty
GPM820N20NTB	TO-220-3L-C	M820N20N	Tube	NA	NA	50pcs

ABSOLUTE MAXIMUM RATINGS ($T_A = 25^\circ\text{C}$ unless otherwise noted)

Parameter	Symbol	Value	Unit
Drain - Source Voltage	V_{DS}	200	V
Gate - Source Voltage	V_{GS}	±30	V
Continuous Drain Current ¹	I_D	$T_C = 25^\circ\text{C}$	28
		$T_C = 100^\circ\text{C}$	18
Pulsed Drain Current ²	I_{DM}	112	A
Single Pulsed Avalanche Current ³	I_{AS}	45	A
Single Pulsed Avalanche Energy ³	E_{AS}	506	mJ
Power Dissipation ⁵	P_D	208	W
Thermal Resistance from Junction to Ambient ⁶	$R_{\theta JA}$	61	$^\circ\text{C/W}$
Thermal Resistance from Junction to Case	$R_{\theta JC}$	0.6	$^\circ\text{C/W}$
Junction Temperature	T_J	150	$^\circ\text{C}$
Storage Temperature	T_{STG}	-55~ +150	$^\circ\text{C}$

MOSFET ELECTRICAL CHARACTERISTICS ($T_A = 25^\circ\text{C}$ unless otherwise noted)

Parameter	Symbol	Test Condition	Min	Type	Max	Unit
Off Characteristics						
Drain-Source Breakdown Voltage	$V_{(BR)DSS}$	$V_{GS} = 0V, I_D = 250\mu A$	200			V
Zero Gate Voltage Drain Current	I_{DSS}	$V_{DS} = 200V, V_{GS} = 0V$			1	μA
Gate-Body Leakage Current	I_{GSS}	$V_{GS} = \pm 30V, V_{DS} = 0V$			± 100	nA
On Characteristics⁴						
Gate Threshold Voltage	$V_{GS(th)}$	$V_{DS} = V_{GS}, I_D = 250\mu A$	2.7	3.1	3.5	V
Drain-Source On-Resistance	$R_{DS(on)}$	$V_{GS} = 10V, I_D = 10A$		81	105	m Ω
Dynamic Characteristics						
Input Capacitance	C_{iss}	$V_{DS} = 100V, V_{GS} = 0V, f = 1MHz$		1630		pF
Output Capacitance	C_{oss}			172		
Reverse Transfer Capacitance	C_{rss}			17		
Gate Resistance	R_g	$V_{DS} = 0V, V_{GS} = 0V$		1.7		Ω
Switching Characteristics						
Total Gate Charge	Q_g	$V_{DS} = 100V, V_{GS} = 10V, I_D = 28A$		35		nC
Gate-Source Charge	Q_{gs}			11		
Gate-Drain Charge	Q_{gd}			14		
Turn-On Delay Time	$t_{d(on)}$	$V_{DD} = 100V, V_{GS} = 10V, I_D = 28A$ $R_G = 24\Omega$		20		ns
Turn-On Rise Time	t_r			75		
Turn-Off Delay Time	$t_{d(off)}$			77		
Turn-Off Fall Time	t_f			60		
Source-Drain Diode Characteristics						
Diode Forward Voltage ⁴	V_{SD}	$V_{GS} = 0V, I_S = 10A$			1.2	V

Notes :

- 1.The maximum current rating is limited by package.And device mounted on a large heatsink
- 2.Pulse Test : Pulse Width $\leq 10\mu s$, duty cycle $\leq 1\%$.
- 3.EAS condition: $V_{DD} = 100V, V_{GS} = 10V, L = 0.5mH, R_G = 25\Omega$ Starting $T_J = 25^\circ\text{C}$.
- 4.Pulse Test : Pulse Width $\leq 300\mu s$, duty cycle $\leq 2\%$.
- 5.The power dissipation P_D is limited by $T_{J(MAX)} = 150^\circ\text{C}$.And device mounted on a large heatsink
- 6.Device mounted on $1in^2$ FR-4 board with 2oz. Copper, in a still air environment with $T_A = 25^\circ\text{C}$.

Typical Characteristics

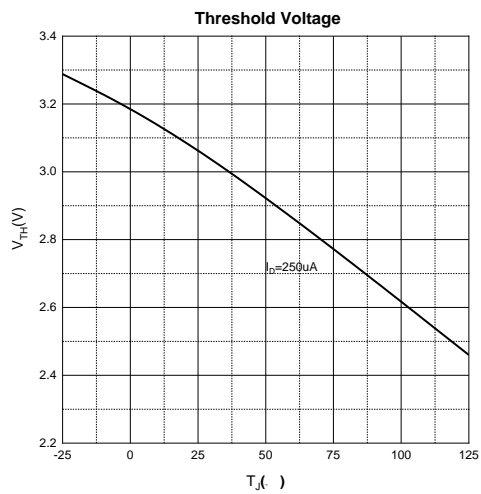
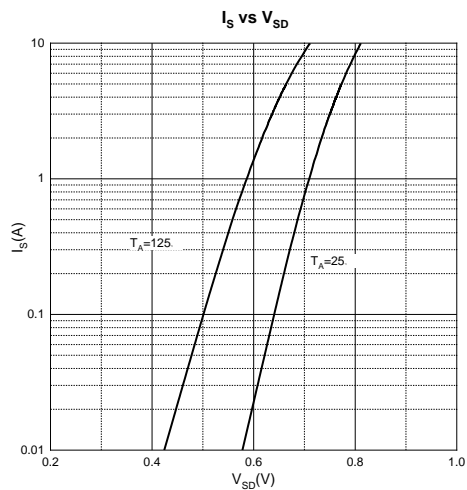
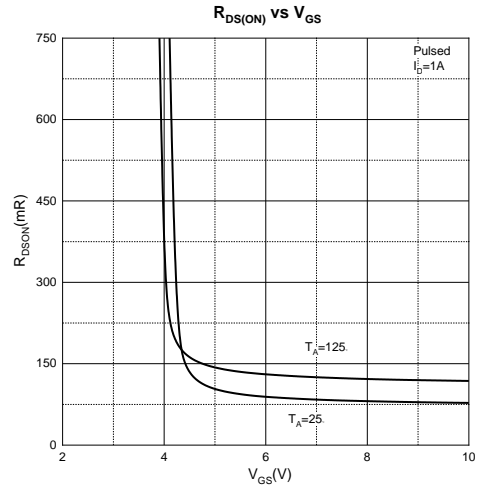
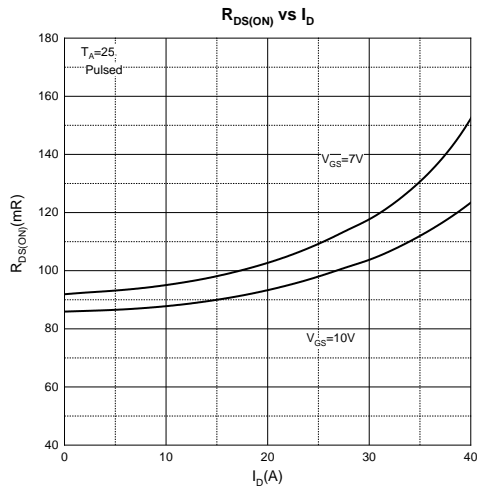
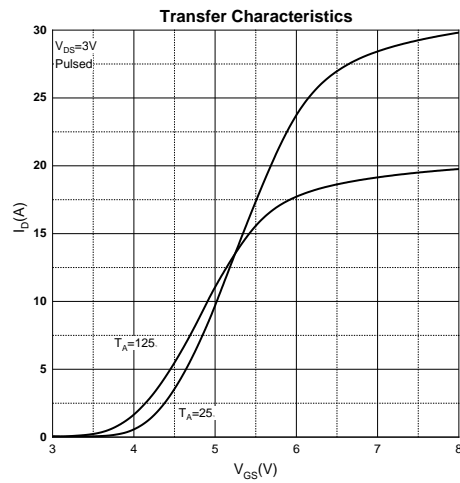
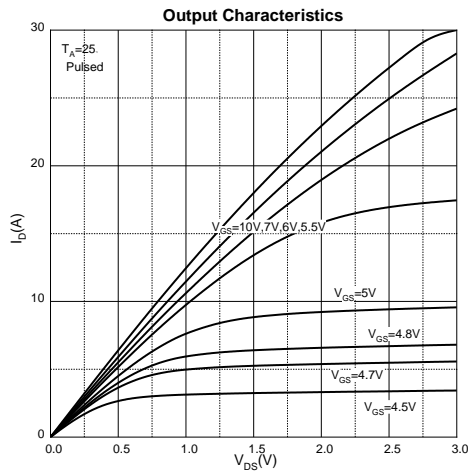

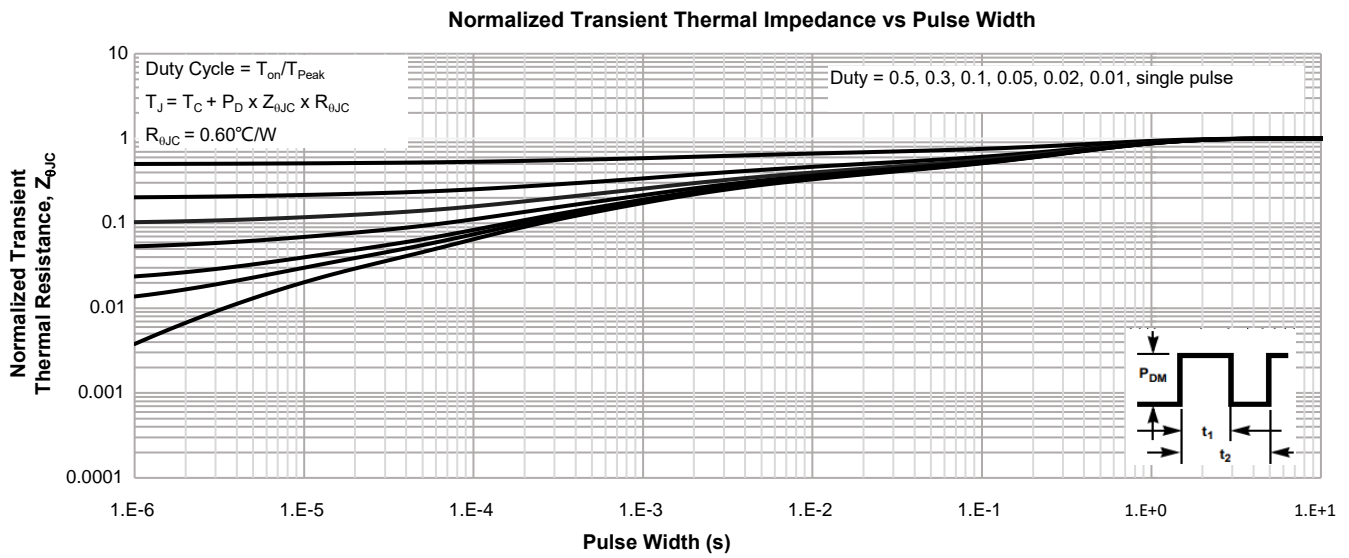
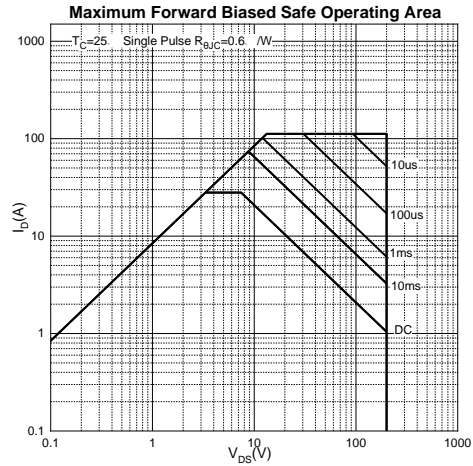
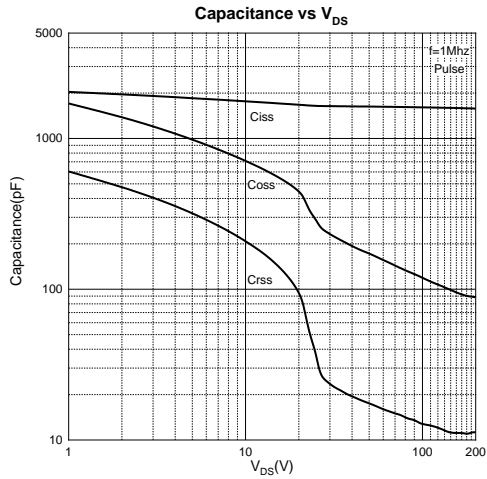

Gate Charge Test Circuit & Waveform

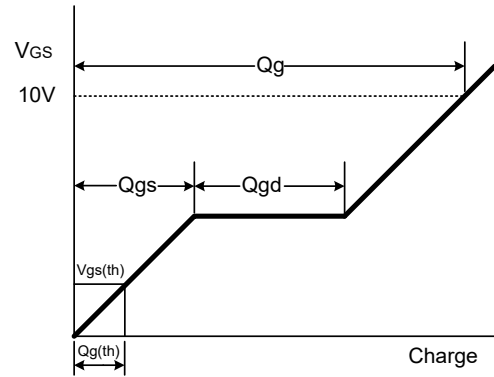
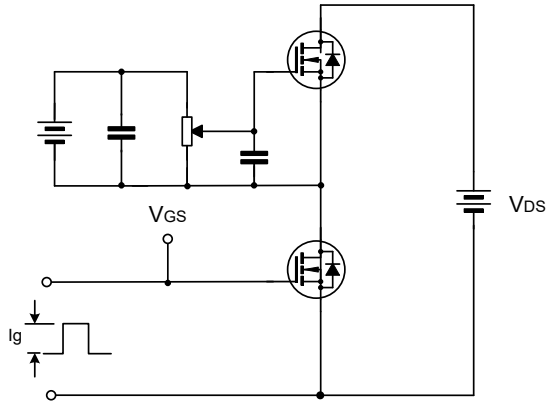

Resistive Switching Test Circuit & Waveform

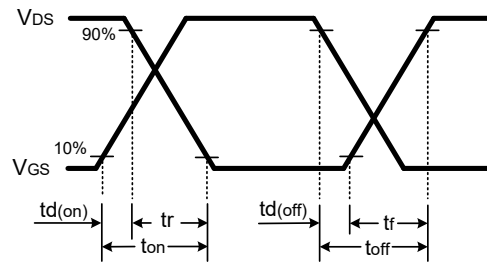
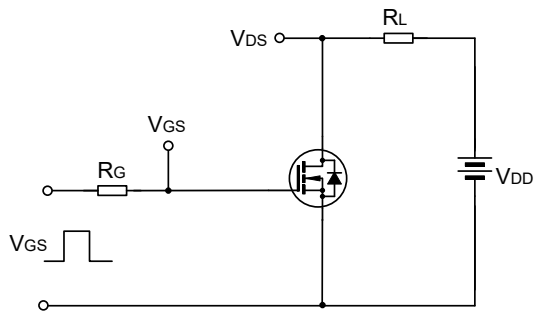

EAS Test Circuit & Waveform

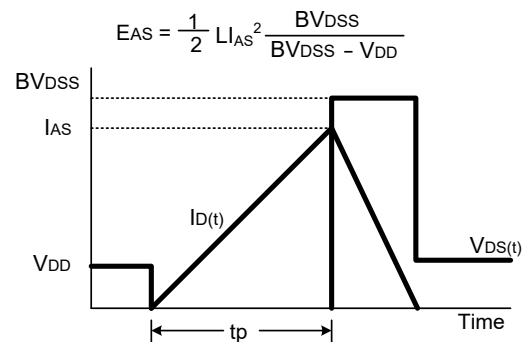
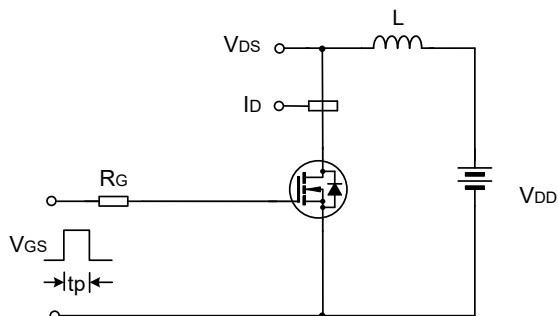

TO-220-3L-C Package Information

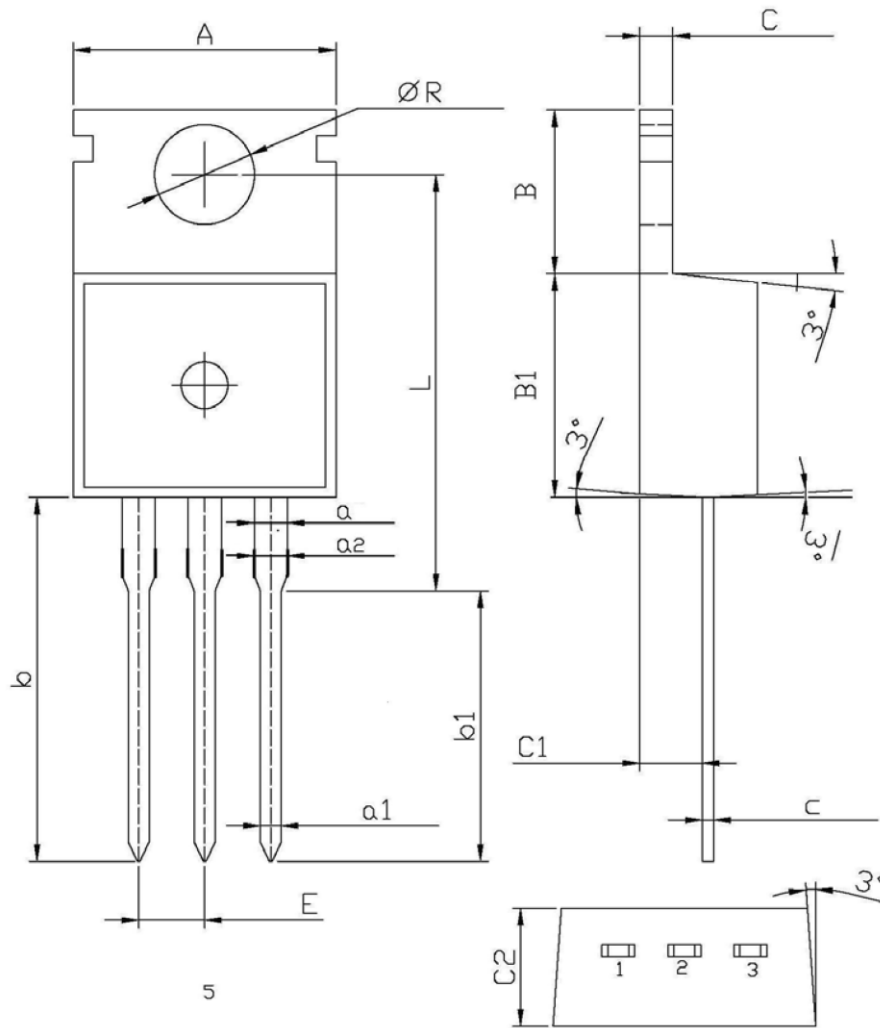

Symbol	Dimensions In Millimeters		Dimensions In Inches	
	Min.	Max.	Min.	Max.
A	9.800	10.200	0.386	0.402
R	3.560	3.640	0.140	0.143
L	15.700	16.100	0.618	0.634
b	12.600	13.600	0.496	0.535
b1	9.600	10.600	0.378	0.417
a	1.220	1.320	0.048	0.052
E	2.340	2.740	0.092	0.108
a2	1.250	1.620	0.049	0.064
C	1.200	1.400	0.047	0.055
B	5.900	6.700	0.232	0.264
B1	9.000	9.400	0.354	0.370
C1	2.200	2.600	0.087	0.102
a1	0.700	0.900	0.028	0.035
c	0.400	0.600	0.016	0.024
C2	4.300	4.700	0.169	0.185

Attention:

- GreenPower Electronics reserves the right to improve product design function and reliability without notice.
- Any and all semiconductor products have certain probability to fail or malfunction, which may result in personal injury, death or property damage. Customer are solely responsible for providing adequate safe measures when design their systems.
- GreenPower Electronics products belong to consumer electronics or other civilian electronic products.